

MOLINARI



SINGLE SHAFT SHREDDERS  
**TPm SERIES**

# TPm SERIES

## Strengths

OPTIMAL PERFORMANCE IN TERMS OF ENERGY SAVING, MAINTENANCE AND PRODUCTIVITY

HOMOGENEOUS DIMENSIONS OF THE GROUND PRODUCT

ROBUSTNESS AND RELIABILITY LONG TERM

POSSIBILITY TO CHANGE THE WORKING PARAMETERS AUTONOMOUSLY OR TO FOLLOW THE PRESET WORKING CYCLES

TELEASSISTANCE SERVICE

# TPm SERIES

## *Single Shaft Shredders*

THE TPM SINGLE SHAFT SHREDDER IS THE PERFECT MACHINE FOR THE SHREDDING SECTOR.

THE TRAPEZOIDAL BLADES AND THE LOW ROTATIONAL SPEED GUARANTEE AN OPTIMAL PERFORMANCE IN TERMS OF ENERGY CONSUMPTION, PRODUCTION AND MAINTENANCE.

THE STRUCTURE OF THE MACHINE IS MADE OF VERY THICK PLATES, IN ORDER TO GUARANTEE LONG TERM ROBUSTNESS AND RELIABILITY.

A PRESSOR GUARANTEES THE SHREDDING OF BIG DIMENSIONS MATERIAL, AVOIDING ITS CLOGGING. THE MOTORIZATION VARIES ACCORDING TO THE TYPE OF MATERIALS TO SHRED.

A SCREEN IS INSTALLED UNDER THE ROTORS. UNLIKE OTHER SHREDDERS ON THE MARKET, IT'S POSSIBLE TO GET A FINAL HOMOGENOUS GROUND PRODUCT ACCORDING TO THE DIMENSIONS OF THE CHOSEN SCREEN. THE DIMENSIONS OF THE HOLES OF THE SCREEN VARY FROM A RANGE OF 40 TO 400MM. THE PRODUCTIVITY VARIES ACCORDING TO THE DIMENSIONS OF THE SCREEN ITSELF: THE HOURLY OUTPUT INCREASES TOGETHER WITH THE SIZE OF THE HOLE.

THE PLC ALLOWS THE CUSTOMER TO MODIFY CERTAIN OPERATING PARAMETERS AUTONOMOUSLY, OR TO FOLLOW A PRE-SET WORKING CYCLE.

**A****ADJUSTABLE TRAVERSE**

THE FIXED AND THE ROTARY BLADES ARE MOUNTED ON AN ADJUSTABLE TRAVERSE IN ORDER TO ALWAYS HAVE AN OPTIMAL CUTTING QUALITY.

**B****PRESSOR**

THE PRESSOR GUARANTEES THE GRINDING OF LIGHT AND HEAVY METATERIALS.

**C****TRAPEZOIDAL BLADES**

TOGETHER WITH THE LOW ROTATIONAL SPEED, THEY GUARANTEE OPTIMAL PERFORMANCE IN TERMS OF ENERGY SAVING, PRODUCTIVITY AND MAINTENANCE.

**D****STRUCTURE**

THE STRUCTURE OF THE MACHINE IS MADE OF THICK ELECTROWELDED PLATES, ABLE TO ENSURE ROBUSTNESS AND RELIABILITY LONG TERM.

**E****HIDRAULIC MOTOR**

HYDRAULIC MOTOR WITH AN HYDRAULIC UNIT CONNECTED TO A GEARBOX.

**F****SCREEN**

UNLIKE OTHER SHREDDERS ON THE MARKET, A SCREEN IS INTALLED UNDER THE ROTORS. THE SCREEN ALLOWS TO OBTAIN A GROUND PRODUCT VERY HOMOGENEOUS AND DEFINITELY SIZE, ACCORDING TO THE THE HOLES OF THE SCREEN ITSELF. THE DIAMETER OF THE SQUARED HOLES CAN RANGE FROM 40 TO 400MM. THE HOURLY OUTPUT INCREASES TOGETHER WITH THE SIZE OF THE HOLES.

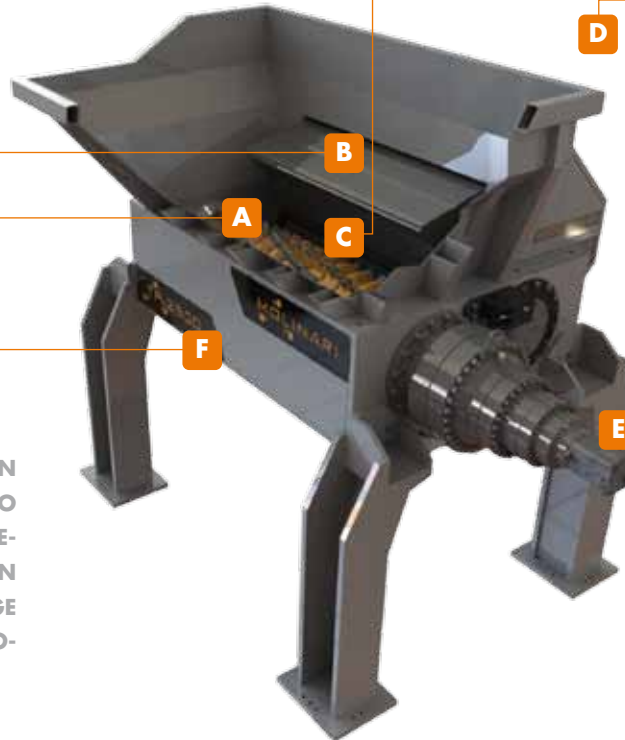

# TPm SERIES

## Technical Features

|                  | TPm1200                                     | TPm2000                                   | TPm2500                                     |
|------------------|---|---|---|
| DIMENSIONS       | 1200  | 6.200 X 2.850 X 3.720 MM                  | 6.200 X 2.850 X 3.720 MM                    |
| LOADING HOPPER   | CUSTOM MADE                                 | 2.840 X 3.800 MM                          | 2.800 X 4.300 MM                            |
| GRINDING CHAMBER | 4.700 X 1.700 MM                            | 2.000 X 1.200 MM                          | 2.500 X 1.200 MM                            |
| WEIGHT           | 12 TON                                      | 30 TON                                    | 34 TON                                      |
| SHAFTS           | NR. 1, DIAMETER 570 MM,<br>LENGTH 1200 MM   | NR. 1, DIAMETER 826 MM,<br>LENGTH 2000 MM | NR. 1, DIAMETER 826 MM,<br>LENGTH 2500 MM   |
| SPEED            | 0-30 RPM                                    | 0 - 30 RPM                                | 0 - 30 RPM                                  |
| POWER            | 1 HYDRAULIC MOTOR<br>WITH A 110-160 KW UNIT | 1 HYDRAULIC MOTOR<br>WITH A 200 KW UNIT   | 1 HYDRAULIC MOTOR<br>WITH A 250-315 KW UNIT |
| GEARBOX          | NR. 1                                       | NR. 1                                     | NR. 1/2                                     |
| SCREEN           | HOLES FROM 20 TO 40 MM                      | HOLES FROM 40 TO 400 MM                   | HOLES FROM 40 TO 400 MM                     |



### MOLINARI S.R.L.

VIA DELL'INDUSTRIA, 4  
24010 LENNA (BERGAMO) ITALY  
TEL. +39.0345.31.78.01  
FAX +39 0345.31.78.27  
INFO@MOLINARI-RECYCLING.COM

NEAREST AIRPORT:  
BGY (BERGAMO)

HIGHWAY EXIT:  
A4 DALMINE / BERGAMO

